

Establishing the Independent Culture of a Strictly Symbiotic Bacterium *Symbiobacterium thermophilum* from Its Supporting *Bacillus* Strain

Michiyo OHNO, Itsuho OKANO, TOMO-O WATSUJI, Teruhito KAKINUMA, Kenji UEDA, and Teruhiko BEPPU[†]

Department of Applied Biological Sciences, College of Bioresource Sciences, Nihon University, Kameino 1866, Fujisawa-shi, Kanagawa 252-8510, Japan

Received February 15, 1999; Accepted February 16, 1999

Symbiobacterium thermophilum is a strictly symbiotic thermophile, the growth of which is dependent on the coexistence of an associating thermophilic *Bacillus* sp., strain S. *S. thermophilum* grows only in mixed culture with the *Bacillus* strain in liquid media, and does not form visible colonies on solid media. To measure the growth of this symbiotic bacterium and to analyze its growth requirements, we developed a quantitative PCR method by using its specific sequences in a putative membrane translocator gene *tnaT* as primers. According to this method, independent growth of *S. thermophilum* was first confirmed in a dialyzing culture physically separated from *Bacillus* strain S with a cellulose membrane. Independent growth of *S. thermophilum* was also managed by adding conditioned medium prepared from the culture filtrate of the *Bacillus* strain, but the growth in the conditioned medium stopped at a very limited extent with appearance of filamentous cells, suggesting the uncoupling of cellular growth and cell division. Formation of micro-colonies of *S. thermophilum* was observed on the conditioned agar medium under both aerobic and anaerobic conditions, but the colony-forming efficiencies remained below 1%. Several other bacterial species, such as *Bacillus stearothermophilus*, *Bacillus subtilis*, *Thermus thermophilus*, and even *Escherichia coli*, were also found to support the growth of *S. thermophilum*. These results indicate that *S. thermophilum* essentially requires some ubiquitous metabolite(s) of low molecular weight produced by various bacterial species as growth factor(s) but coexistence of the living partner cells is still required, probably to maintain an effective level of the putative factor(s) in the medium.

Key words: microbial symbiosis; *Symbiobacterium*; quantitative PCR; growth factor

Symbiobacterium thermophilum is a thermophilic bacterium in a small rod form, which was discovered in compost as a producer of heat-stable enzymes such as tryptophanase¹⁻³⁾ and β -tyrosinase.^{4,5)} The organism was obtained in mixed culture with another thermophilic bacterium, *Bacillus* strain S, in liquid media, but all attempts to establish its axenic culture were unsuccessful. No pure colonies nor the independent growth of *S. thermophilum* had been observed in any artificial media so far examined, while the associating *Bacillus* strain grew

independently and formed colonies on the usual nutrient broth agar. Growth of *S. thermophilum* was only observed when *Bacillus* strain S was in the liquid mixed culture, where *Bacillus* started to grow first and growth of *S. thermophilum* followed later. No physical association between the cells of the two organisms was observed in the mixed culture. These two bacteria compose a defined system with parasitic interaction that may be assumed as an example of the symbiotic systems between multiple free-living microbial strains.

Although the growth profiles of *S. thermophilum* in the mixed culture suggested a possible involvement of some diffusible growth factor(s) produced by the *Bacillus* cells, detection of the putative factor has hitherto been hampered because of the inability of *S. thermophilum* to form colonies. Quantitative estimation of the growth should depend on direct cell counting under a microscope, but the method was not sufficient for the reliable and specific measurements to distinguish possible contaminating organisms from *S. thermophilum*. To overcome this difficulty, we adopted the polymerase chain reaction (PCR) with specific DNA sequences of *S. thermophilum* as primers, which allowed us to detect and measure the cell mass without cultivation.⁶⁾ This method enabled us to distinguish growth of *S. thermophilum* from that of *Bacillus* strain S with high specificity. By using this method, we succeeded in detecting independent growth of *S. thermophilum* in a dialyzing culture with *Bacillus* strain S. It was also possible to infer the presence of the growth promoting factor(s) in the culture filtrates of the supporting organisms. This paper deals with these results along with several characteristic features of the independent culture of *S. thermophilum*.

Materials and Methods

Strains, media, and cultivation. Liquid mixed culture of *S. thermophilum* and *Bacillus* strain S was done in 50 ml of LB broth [1% Bacto tryptone (Difco), 0.5% Bacto yeast extract (Difco), and 0.5% NaCl, pH 6.8] in a 200-ml Erlenmeyer flask and cultured at 60°C without shaking. Overnight culture containing both organisms at approximately the same cell concentrations ($1-5 \times 10^8$ cells/ml) was centrifuged at $4,000 \times g$ for 25 min, and the cells resuspended in 50 mM sodium phosphate buffer

[†] To whom correspondence should be addressed. Tel: +81-466-84-3931; Fax: +81-466-84-3935; E-mail: beppu@brs.nihon-u.ac.jp
Abbreviation: PCR, polymerase chain reaction

(pH 7.0) were kept at -80°C for inoculation into the next mixed cultures. To obtain the inoculum for the independent culture of *S. thermophilum* in the dialyzing culture vessel described below, the mixed culture was continued for 42 h or more to reach the late stationary phase. At this stage the viable cell number of *S. thermophilum* became highly dominant to that of *Bacillus* by 10^3 times or more due to the selective killing of *Bacillus* by indole accumulated in the medium.¹⁾ Viable cell numbers of *S. thermophilum* in these cultures were estimated from the maximum dilution ratios to cause its growth in liquid subcultures as follows. Samples were diluted to give a series of diluted cell suspensions by 10^4 – 10^9 times. A portion (0.2 ml) from the each diluted suspension was inoculated into a test tube containing 1.8 ml of LB broth, which was additionally inoculated with a separately prepared pure culture of *Bacillus* strain S at a concentration of 2×10^6 cells/ml to support the growth of *S. thermophilum*. After 2 days of incubation at 60°C , *S. thermophilum* growth in the subcultures was monitored by adding Kovack's reagent to check indole production by its tryptophanase activity.¹⁾ The maximum dilution ratio to give the indole production represented the viable cell number of *S. thermophilum* in the original sample. The number thus estimated was at the order of 10^9 cells/ml in the late stationary phase of the mixed culture. Viable cell numbers of *Bacillus* strain S in the same culture were measured by colony counting on LB broth agar, which were usually about 1×10^6 cells/ml. Then the late stationary culture was diluted with a magnitude (10^6 times for example) to minimize accompanying incorporation of *Bacillus* strain S and used for inoculation of the dialyzing culture. The independent culture thus obtained was used as the inocula of *S. thermophilum* for further experiments.

Pure culture of *Bacillus* strain S was done in 100 ml of LB broth in a 300 ml Erlenmeyer flask with gentle shaking at 60°C . To prepare conditioned medium to examine the cell-free activity to support independent growth of *S. thermophilum*, the overnight culture of *Bacillus* strain S was centrifuged, and the resultant supernatant was supplemented with 1% Bacto tryptone and 0.5% Bacto yeast extract and adjusted to pH 7.5. The enriched supernatant filtered with a Millipore membrane (pore size $0.22 \mu\text{m}$; Millex-GP) was aseptically mixed with LB broth adjusted to pH 7.5 at appropriate ratios, and the mixtures were used as conditioned media. Conditioned agar medium for colony formation of *S. thermophilum* was prepared by adding 2% agar (Difco) to the conditioned medium containing 50% (v/v) of the enriched culture filtrate and autoclaved. *Escherichia coli* JM105 was similarly examined as to the activity in the culture filtrates. To examine the activity of the conditioned medium of *Saccharomyces cerevisiae* hER,⁷⁾ the yeast was cultured in LB broth (pH 5.5) for 48 h at 25°C without shaking and the culture filtrate was analyzed as to the activity after adjusting pH to 7.5. *Bacillus subtilis* 1012,⁸⁾ *Bacillus stearothermophilus* SICI,⁹⁾ and *Thermus thermophilus* TH125¹⁰⁾ were examined as to their abilities to support growth of *S. thermophilum* in mixed cultures. The mixed cultures were

done in LB broth without shaking mostly at 60°C with the exception of *B. subtilis*–*S. thermophilum* mixed culture, which was incubated at 51°C .

Dialyzing culture vessel. To detect the activity of a putative growth factor for *S. thermophilum* produced by *Bacillus* strain S, a glass vessel illustrated in Fig. 1 was designed. The vessel consists of two parts, each of which has a cotton-plugged inlet and an open cut with a flat edge for fitting the two parts together, and the assembled vessel could contain approximately 100 ml of media in total. A cellulose dialyzing membrane with a diameter of 45 mm prepared from a dialysis membrane tube (Spectra/Pro Membrane, molecular weight cut-off, 3,500 Da; Spectrum) was placed between the flat edges to separate liquid medium in the two partitions. After assembling the parts and membrane together, the outside edges were wrapped with silicon tape to assure sealing, and the parts were harnessed with springs. The vessel containing 50 ml of LB broth in each partition was autoclaved, and *S. thermophilum* from the late stationary phase of the mixed culture described above and the pure culture of *Bacillus* strain S were inoculated into each partition respectively. The inoculated vessel was incubated without shaking at 60°C .

Quantitative PCR to measure growth of *S. thermophilum* and *Bacillus* strain S. PCR for specific gene sequences of *S. thermophilum* or *Bacillus* strain S was used to detect and measure their growth. *tnaT* is a gene encoding a homologue of eukaryotic membrane translocators belonging to the sodium-dependent neurotransmitter family (SNF),¹¹⁾ which was identified in the tryptophanase operon of *S. thermophilum* (our unpublished data). The nucleotide sequence of *tnaT* has been submitted to DDBJ, EMBL, and GenBank under the accession number AB010832. The product TnaT is a 55-kDa protein sharing 32% identity with a rat betaine/GABA transporter.¹²⁾ Two sequences in the *tnaT* coding sequence, nt. 778–792 (5'-CGTCTTCGCAACTCA-3') and nt. 972–958 (5'-CAGGATACCGAACAG-3'), were synthesized and used as primers in PCR. As a specific probe for *Bacillus* strain S DNA, the phosphotransferase system enzyme I (*ptsI*) gene cloned from the strain was used (our unpublished data, accession No.

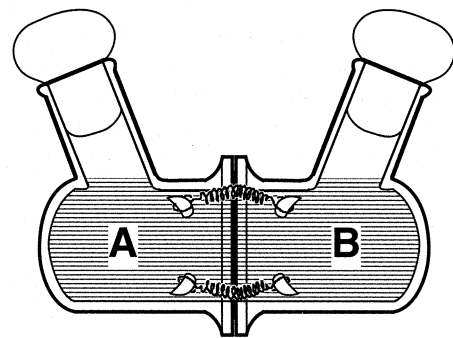

Fig. 1. A Dialyzing Culture Vessel Separated into Two Partitions A and B by a Cellulose Membrane.

AB016285). The gene shared 97.6% identity with that of *B. stearothermophilus*.¹³ The sequences corresponding to nt. 439–452 (5'-CTGCTTGGCGTCAC-3') and nt. 698–685 (5'-ACTTGGCCGTCGAG-3') in the *ptsI* were synthesized and used as primers. Forward primers for both *tnaT* and *ptsI* sequences were labeled with Cy5 (Amersham Life Science) to allow detection of their amplified products by fluorescence.

Cell suspension samples were treated for PCR as follows. A sample (100 μ l) of cell suspension was added to 1 μ l of DNase I solution (10 units/ μ l; Boehringer Mannheim) and 9 μ l of the buffer containing 125 mM MgSO₄ and 20 mM MOPS, pH 6.8. The mixture was incubated at 37°C for 30 min to remove extracellular DNA contaminants, and then heated at 100°C for 5 min to inactivate the enzyme. The mixture was frozen at -20°C for 60 min and then boiled for 10 min. For cell lysis, 2 μ l of Proteinase K solution (0.3 units/ μ l; Promega) and 28 μ l of the buffer containing 0.5% (v/v) Tween 20, 0.1% (v/v) Nonidet P-40, 0.3 mM EDTA, and 20 mM Tris-HCl, pH 8.0, were added. After incubation for 1 h at 60°C, the lysate was boiled for 10 min and centrifuged at 17,000 $\times g$ for 5 min. The resultant supernatant was tested by quantitative PCR as follows. A sample (10 μ l) of the supernatant was added to 25 pmoles of the primers described above, 10 nmoles each of deoxyribonucleotides, and 2.5 units of polymerase (*TaKaRa Ex Taq*; Takara) in 50 μ l of 1 \times *Ex Taq* buffer. The reaction was done by the following schedule: 3 min at 94°C – [1 min at 94°C – 1 min at 50°C – 2 min at 72°C] \times 30 cycles – 3 min at 72°C. The amplified products were electrophoresed on a polyacrylamide gel (8% gel concentration), and densities of the amplified DNA bands (194 bp for *tnaT* and 259 bp for *ptsI*, respectively)

were analyzed by fluorometry using an Image Analyzer (STORM; Molecular Dynamics). To correct fluctuation of the amplification between different PCR analyses, several samples containing the microscopically counted cells in the range of 1×10^5 to 5×10^6 cells/ml were simultaneously analyzed as standards in each analysis.

Colony formation of *S. thermophilum*. Cells of *S. thermophilum* free from *Bacillus* strain S were plated onto conditioned agar medium prepared from the culture filtrate of *Bacillus* strain S and incubated at 60°C for 2–6 days. To observe micro-colonies of *S. thermophilum*, the surface of the plates was carefully observed with a phase-contrast microscope at $\times 100$ magnification. In order to examine colony formation under the anaerobic conditions, the plates were incubated at 60°C in a BBL Gaspack Pouch (Becton Dickinson Microbiology Systems), which generated an anaerobic atmosphere with less than 2% oxygen and a carbon dioxide concentration of greater than 4%.

Results

Development of quantitative PCR to measure growth of *S. thermophilum*

S. thermophilum has two similar genes both encoding heat-stable tryptophanases, called *tna1* and *tna2*, which are closely located in tandem in the chromosome.³ Sequence analysis of the flanking regions showed the presence of an open reading frame, *tnaT*, encoding a sequence similar to those of eukaryotic membrane translocators known as SNF. Recent genome sequencing projects of several bacterial species have found a similar sequence in *Haemophilus influenzae*¹⁴ and *Methanococcus jannaschii*¹⁵ but not in *Escherichia coli* nor *B. subti-*

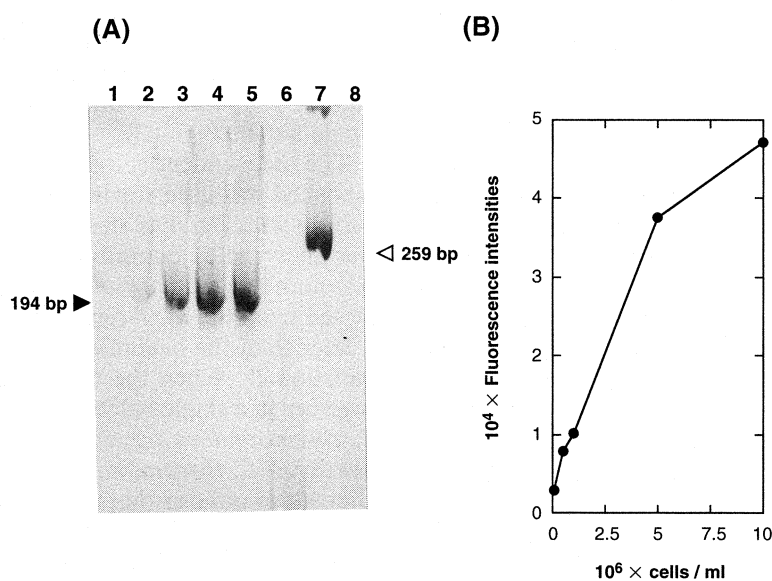

Fig. 2. Quantitative PCR of the *tnaT* Sequence with a Series of the Diluted Cell Suspension of *S. thermophilum*.

(A) Gel electrophoresis of the amplified products by PCR. Lanes 1 to 5 are the *tnaT* signals obtained from *S. thermophilum* cells at 1×10^5 , 5×10^5 , 1×10^6 , 5×10^6 , and 1×10^7 cells/ml, respectively. Lane 6 is the *ptsI* signals from 1×10^7 cells/ml of *S. thermophilum*. Lanes 7 and 8 are the controls of 1×10^7 cells/ml of *Bacillus* strain S analyzed by using the *ptsI* and *tnaT* primers, respectively. Closed and open arrows indicate positions of the *tnaT* and *ptsI* signals, respectively. (B) Plots of relative fluorescence intensities of the *tnaT* signal versus cell densities of *S. thermophilum*.

lis. We used parts of this characteristic sequence as primers of PCR to measure DNA and cells of *S. thermophilum*. We have also cloned a sequence similar to that of the enzyme I gene (*ptsI*) of the phosphotransferase system for hexose transport from *Bacillus* strain S. We used parts of this sequence as specific primers to detect growth of *Bacillus* strain S.

S. thermophilum cells recovered from the late stationary phase of the mixed culture were serially diluted, and the diluted samples were analyzed by quantitative PCR with *tnaT* primers. As shown in Fig. 2A and B, densities of the amplified DNA bands increased proportionally within a range from 1×10^5 to 5×10^6 cells/ml or more. No *ptsI* signal was observed with the highest concentration of *S. thermophilum* cells. On the other hand, a strong amplified signal of *ptsI* was observed with the suspension of *Bacillus* strain S at 1×10^7 cells/ml, while no amplified band of *tnaT* was detected (Fig. 2A). Thus both primers were confirmed to be sufficiently specific to measure growth of each partner respectively. The minimum concentrations allowing detection of both organisms by PCR was approximately 5×10^4 cells/ml.

This method was used to measure growth of *S. thermophilum* and *Bacillus* strain S in the mixed culture. When an overnight mixed culture of *S. thermophilum* and *Bacillus* strain S was inoculated into fresh LB broth, a rapid increase in the *ptsI* signal of *Bacillus* strain S started to occur first, which was followed by a slow increase in the *tnaT* signal as shown in Fig. 3A. The maximum cell density of *S. thermophilum* in the mixed culture was estimated to be 2×10^9 cells/ml. The result was essentially the same as that obtained by microscopic cell counting (Fig. 3B). The estimated values of *Bacillus* by PCR decreased in the later stage, probably due to the autolytic degradation of cellular DNA. Viable cell number of *Bacillus* by colony counting at 42 h was 1.2×10^6 cells/ml, which was far lower than both estimations, those by PCR and microscopic counting.

Dialyzing culture of *S. thermophilum* physically separated from *Bacillus* strain S

Although a mixed culture with *Bacillus* strain S had hitherto been the only way to grow *S. thermophilum*, the growth profiles suggested involvement of some essential growth factor(s) which was produced by the *Bacillus* cells and provided for *S. thermophilum* through diffusion. In order to establish an axenic culture of *S. thermophilum* probably requiring such a putative growth factor, a dialyzing culture vessel partitioned by a cellulose membrane (Fig. 1) was used. *S. thermophilum* cells from the late stationary phase of the mixed culture was inoculated into LB broth in partition A, which conferred the initial concentration of *S. thermophilum* at about 2×10^3 cells/ml with less than 1 cell/ml of *Bacillus* strain S. Partition B was inoculated with a pure culture of *Bacillus* strain S at early stationary phase at a concentration of 5×10^7 cells/ml. After 4 days incubation at 60°C, a distinct increase in the *tnaT* signal with no signal of *ptsI* was observed in partition A, while an increase in the *ptsI* signal with no signal of *tnaT* was ob-

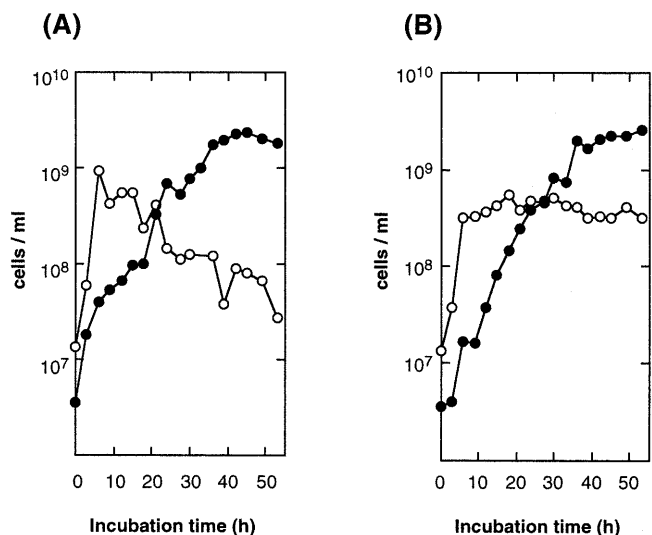

Fig. 3. Growth Curves in the Mixed Culture of *S. thermophilum* and *Bacillus* Strain S Analyzed by (A) Quantitative PCR and (B) Microscopic Cell Counting.

●, cell numbers of *S. thermophilum*; ○, cell numbers of *Bacillus* strain S.

served in partition B (Fig. 4A). Microscopic observation confirmed the marked increase in cell number of *S. thermophilum* in the absence of the *Bacillus* cells in partition A. No colonies of *Bacillus* appeared after plating 0.1 ml of the culture in partition A on LB broth agar, while the *Bacillus* cells added to the culture before the plating as a control at a concentration of 1×10^3 cells/ml formed colonies almost quantitatively. These results confirmed the independent growth of *S. thermophilum* in the absence of *Bacillus* strain S in partition A. When inoculation of *Bacillus* into partition B was omitted, no increase in the *tnaT* and *ptsI* signals was observed in partition A (Fig. 4B). Increase in the *tnaT* signal in the dialyzing culture with *Bacillus* strain S was almost comparable to that in the mixed culture of both strains in a single batch (Fig. 4C).

The independent culture of *S. thermophilum* thus established was used for inoculation of the next dialyzing culture with *Bacillus* strain S and the course of growth was analyzed by quantitative PCR. As shown in Fig. 5, cell numbers of *S. thermophilum* in partition A estimated from the *tnaT* signal started to increase about 24 h later than the beginning of the growth of *Bacillus* in partition B. When the two organisms were inoculated together in a single batch, the lag phase of the growth of *S. thermophilum* became shorter. The maximum cell density of *S. thermophilum* in the dialyzing culture was almost the same as that of the mixed culture. A marked feature of the independent culture of *S. thermophilum* thus achieved in partition A was its low turbidity (OD_{660}), which corresponded to only 1/5 of that conferred by *E. coli* or *B. subtilis* at the same cell concentrations.

Independent growth of *S. thermophilum* supported by the conditioned medium of *Bacillus* strain S

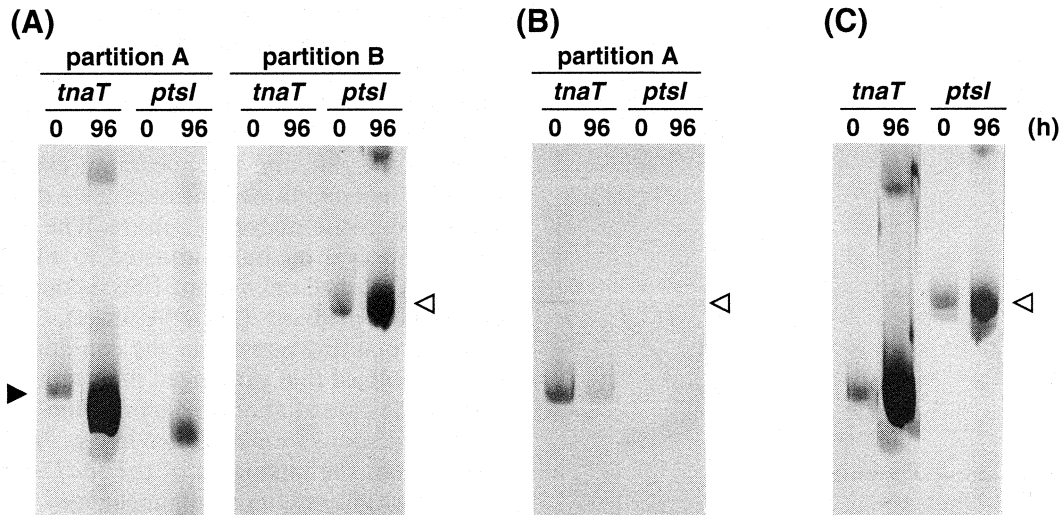

Fig. 4. Gel Electrophoresis of the PCR Products of *tnaT* and *ptsI* in Dialyzing and Mixed Cultures.

Closed and open arrows indicate positions of the *tnaT* and *ptsI* signals, respectively. PCR analyses were done on cultures for 0 and 96 h, respectively. (A) Dialyzing culture where partition A was inoculated with *S. thermophilum* and partition B with *Bacillus* strain S. Both partitions A and B were analyzed with *tnaT* and *ptsI* primers. (B) Dialyzing culture of *S. thermophilum* without inoculation of *Bacillus* strain S into partition B. Partition A was analyzed with *tnaT* and *ptsI*. (C) Mixed culture of *S. thermophilum* and *Bacillus* strain S in a single batch analyzed with *tnaT* and *ptsI*.

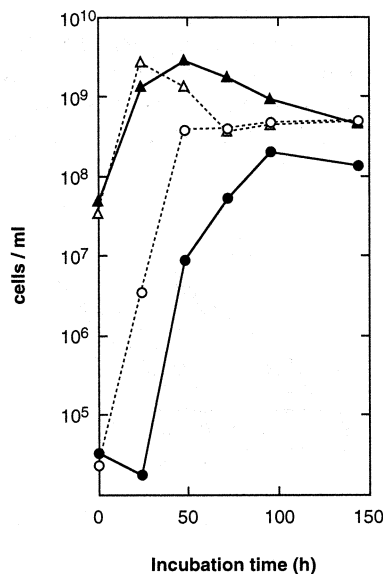

Fig. 5. Growth Curves of *S. thermophilum* and *Bacillus* Strain S in Dialyzing and Mixed Cultures.

S. thermophilum in partition A (●) and *Bacillus* strain S in partition B (▲) in the dialyzing culture (solid lines); *S. thermophilum* (○) and *Bacillus* strain S (△) in the mixed culture (dotted lines).

In order to confirm further the involvement of substantial growth factor(s) in the symbiotic growth of *S. thermophilum*, the effects of conditioned medium prepared from the culture filtrate of *Bacillus* strain S was examined. Fresh LB broth and the conditioned medium were mixed in various ratios and were inoculated with *S. thermophilum* from the dialyzing culture. After incubation for 6 days at 60°C, a distinct increase in the *tnaT* signal without appearance of the *ptsI* signal was observed in the cultures supplemented with more than 30% (v/v)

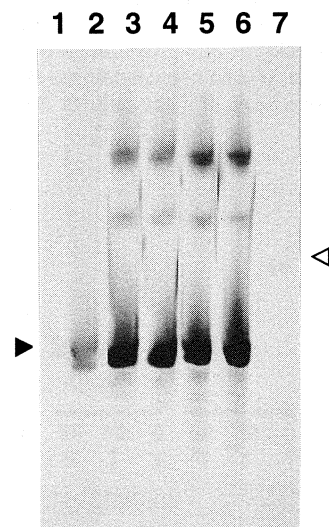

Fig. 6. Gel Electrophoresis of the PCR Products in *S. thermophilum* Cultures with Different Amounts of the Conditioned Medium.

Lanes 1 and 2 are the *tnaT* signals from the cultures in fresh LB broth (pH 6.8) and the broth adjusted to pH 7.5, respectively. Lanes 3 to 6 are the signals from the cultures with LB mixed with 30, 50, 70, and 90% (v/v) of the conditioned medium, respectively. Lane 7 is the *ptsI* signal from the culture with 50% (v/v) of the conditioned medium. The conditioned medium was added to fresh LB broth to give a total volume of 5 ml in 10-ml test tubes of 10 mm diameter. *S. thermophilum* cells were inoculated at a density of 1×10^4 cells/ml. PCR analyses were done after 6 days cultivation.

of the conditioned medium (Fig. 6). It was also observed that only adjusting the initial pH of fresh LB broth (pH 6.8) to 7.5 without adding the conditioned medium caused a very slight increase in the *tnaT* signal. Microscopic observation and plating to examine formation of the *Bacillus* colonies confirmed the absence of

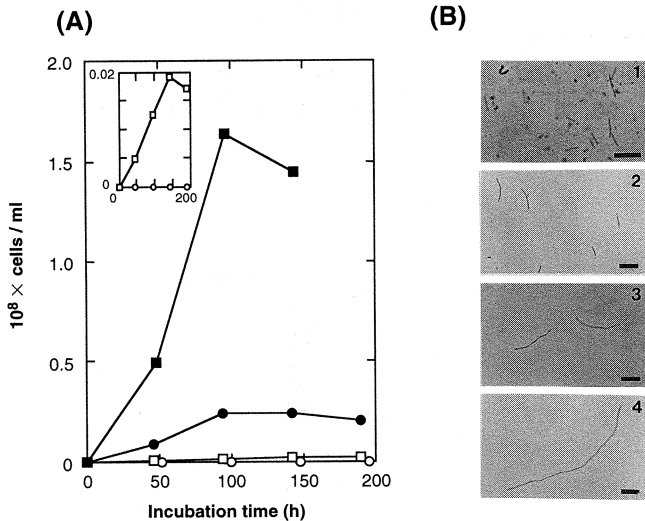

Fig. 7. Growth Curves and Cell Morphology of *S. thermophilum* in the Conditioned Medium.

(A) Courses of growth estimated by PCR in LB broth (pH 6.8) with (●) and without (○) addition of the conditioned medium (50%, v/v); in LB broth (pH 7.5) without addition of the conditioned medium (□); and in the dialyzing culture with *Bacillus* strain S (■). An inset is an enlarged plotting of the growth curves in the non-conditioned media pH 6.8 and pH 7.5. (B) Microscopic photos of (1) *S. thermophilum* cells grown in mixed culture with cell debris of *Bacillus*, and the cells grown in (2) dialyzing culture, (3) conditioned medium, (4) and non-conditioned medium adjusted to pH 7.5. Photos were taken of 4-day cultures. Bars indicate 10 μm .

Bacillus strain S and the independent growth of *S. thermophilum* in the conditioned medium.

The course of the increase in the *tnaT* signal in the conditioned medium was analyzed by PCR and compared to that in the dialyzing culture. As shown in Fig. 7A, both the rate and the maximum extent of the increase in the conditioned medium were distinctly lower than those in the dialyzing culture. The growth in the non-conditioned medium adjusted to pH 7.5 was far lower and reached only about 10% of the growth in the conditioned medium (Fig. 7A inset), so there is a growth-promoting activity in the conditioned medium. We also noticed that prolonged independent cultures in these media caused abnormal elongation of all the cells into a filamentous form as shown in Fig. 7B. The correlation between the intensities of the *tnaT* signal and cell numbers was found to remain unchanged in the filamentous cells, indicating that the cellular DNA contents were kept constant upon elongation of cells. These results suggest that the independent growth of *S. thermophilum* in the absence of the living *Bacillus* cells is limited, probably due to uncoupling of cellular growth and cell division.

Bacterial species other than Bacillus strain S supporting growth of S. thermophilum

Although the ability to support growth of *S. thermophilum* had hitherto been assumed to be a specific property of *Bacillus* strain S,¹⁾ we reexamined the ability of other bacterial species by using the quantitative PCR.

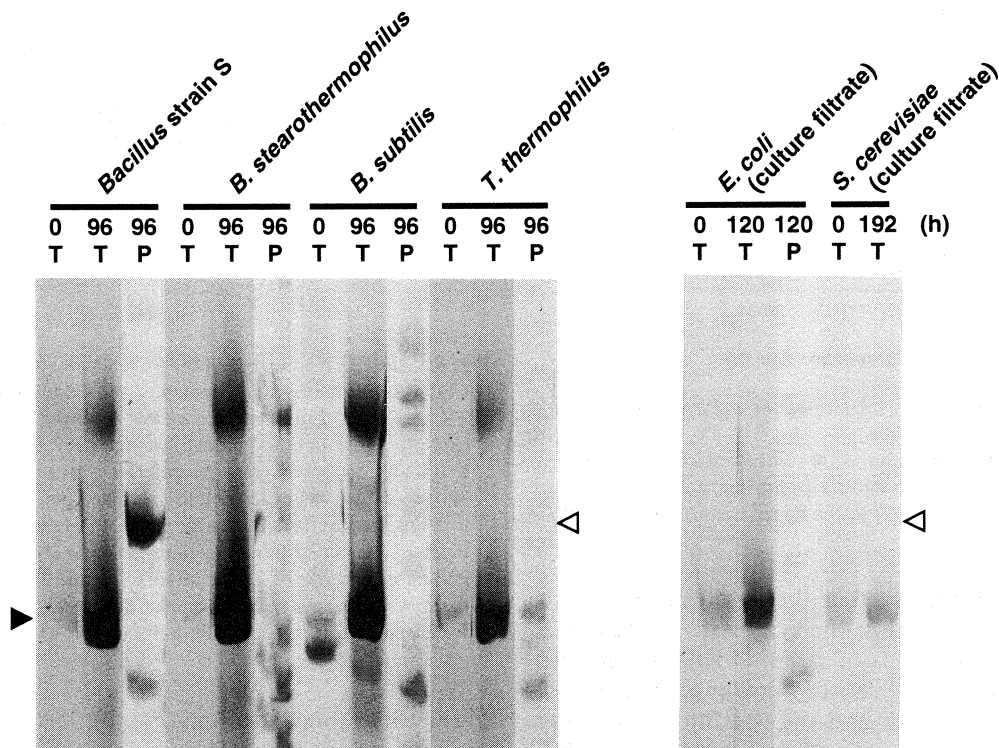

Fig. 8. Growth of *S. thermophilum* Supported by Several Bacterial Species.

S. thermophilum was co-cultured in mixed cultures with *Bacillus* strain S, *B. stearothermophilus*, *B. subtilis*, and *T. thermophilum*, or cultured in the medium with 50% (v/v) of the conditioned medium of *E. coli* or *S. cerevisiae*. Samples were cultured for the hours indicated, and PCR was done with both *tnaT* (lanes T) and *ptsI* (lanes P) primers.

S. thermophilum cells from the dialyzing culture were inoculated into fresh LB broth together with a pure culture of *B. stearothermophilus* or *T. thermophilus*, and incubated at 60°C. Similar mixed culture with *B. subtilis* was done at 51°C, which was chosen as the maximum temperature to allow growth of the mesophilic partner. These mixed cultures were analyzed by PCR by using the *tnaT* and *ptsI* primers, respectively. As shown in Fig. 8, the three species caused distinct increases in the *tnaT* signal, indicating growth of *S. thermophilum*, which was comparable to that with *Bacillus* strain S. The absence of *Bacillus* strain S in the cultures with the two *Bacillus* species and *T. thermophilus* was indicated by the absence of the *ptsI* signal, which was sufficiently specific to distinguish them from *Bacillus* strain S. We also observed that addition of the culture filtrate of *E. coli* to LB broth caused independent growth of *S. thermophilum* as observed with the conditioned medium of *Bacillus* strain S, but the culture filtrate of *S. cerevisiae* showed no such activity (Fig. 8). The possible presence of *Bacillus* strain S in the independent culture with the *E. coli* conditioned medium was excluded by the absence of both the *ptsI* signal and colony formation.

Micro-colony formation of *S. thermophilum*

Based on these observations, colony formation of *S. thermophilum* was examined on the conditioned agar medium prepared from the culture filtrate of *Bacillus* strain S. After incubation for 2–4 days, almost invisible and transparent micro-colonies were found on the agar surface, using a phase-contrast microscope. The maximum size of the colonies was about 0.2 mm even after 6 days of cultivation. Colonies showed irregular form with wrinkled and partially multi-layered surface as shown in Fig. 9A, and colony-forming efficiency against input cell numbers was estimated to be only 0.5–1.0%. When a few tens micro-colonies appearing after 2 days incubation were inoculated into LB broth with the separately cultured *Bacillus* strain S, the liquid mixed culture with potent tryptophanase activity was reproduced. On the other hand, the colonies after 6 days of incubation failed to reproduce the mixed culture, indicating that cells in the colonies lost viability at a later stage of cultivation. Colonies were formed even under anaero-

bic conditions at similar efficiencies, but colony morphology was round with a few marginal rings similar to the layered structure of the aerobic colonies (Fig. 9B). Conditioned medium was also required for colony formation under the anaerobic conditions.

Discussion

S. thermophilum had hitherto been unable to grow independently and its original partner *Bacillus* strain S had been assumed to have a specific activity to support growth of *S. thermophilum*.¹⁾ In this work, however, we discovered that *S. thermophilum* could grow independently in the dialyzing culture with *Bacillus* strain S and in the presence of conditioned media prepared from culture filtrates of various bacterial species. The absence of the original partner *Bacillus* strain S in these cultures was confirmed by (i) the absence of the *ptsI* signal in PCR, (ii) the absence of the *Bacillus* cells by microscopic observations, and (iii) the absence of the *Bacillus* colonies when the cultures were plated on LB broth agar.

Although the non-conditioned medium adjusted to pH 7.5 allowed a very limited independent growth of *S. thermophilum*, addition of the conditioned medium caused distinct growth promotion. It suggests that *Bacillus* plays a role by providing some substance(s) required for growth of *S. thermophilum* but not removing inhibitory substances through their metabolic activities. The independent growth in both the conditioned medium and the non-conditioned medium adjusted to pH 7.5 showed a typical profile of unbalanced growth with marked cellular elongation, which might be due to uncoupling of cellular growth and cell division. The limited sizes and lack of viability of colonies on the conditioned agar medium as well as very low colony-forming efficiencies could be a consequence of the unbalanced growth. These results suggest that cell division is the most vulnerable process in the growth of *S. thermophilum*. The putative growth factor in the conditioned medium may be required to keep the cell division process active, but the effect is apparently not sufficient and the living partner cells are still required to avoid unbalanced growth in a later stage of cultures. A possible explanation for this residual requirement of the living partner cells may be that the putative factor produced in the medium is metabolized by *S. thermophilum* and its constant production or recycling by the living partner cells is required to maintain an effective level in the culture.

The ability to support growth of *S. thermophilum* is not limited to the original associating organism, *Bacillus* strain S, but occurs among a variety of bacterial species, even in the Gram-negative bacteria such as *T. thermophilus* and *E. coli*. The fact that the non-conditioned medium (pH 7.5) caused limited independent growth may suggest that *S. thermophilum* itself also produces the factor but at a very low level. Contrasting to the fact that all bacterial species so far examined showed the activity, we failed to detect it in the culture filtrate of *Saccharomyces cerevisiae*. The growth-supporting factor is assumed to be a low-molecular-mass substance, since the activity is diffusible through a cellulose membrane

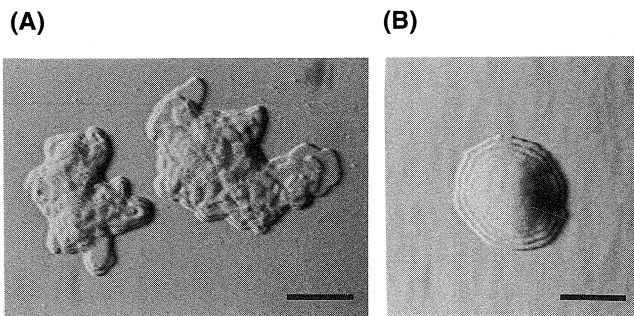

Fig. 9. Micro-colonies of *S. thermophilum* on the Conditioned Agar Medium Observed after 4 Days.
Colonies under (A) the aerobic and (B) the anaerobic conditions. Bars indicate 0.1 mm.

with a molecular cut-off of 3,500 Da. The activity in the conditioned agar medium was not lost by autoclaving, suggesting the putative factor is heat-stable. We have hitherto examined various amino acids, nucleic acid bases, vitamins, and other compounds including glutathione, pyrroloquinolinequinone, and hemin, but no active substance has yet been found. We currently conclude that some low molecular-mass metabolite ubiquitous among at least many bacterial species works as an essential growth factor of *S. thermophilum*.

S. thermophilum was found to be a facultative anaerobe forming colonies under the anaerobic conditions. The growth requirement of *S. thermophilum* suggests that this bacterium and probably its relatives may constitute symbiotic systems not with a specific but a wide range of bacterial species to establish their niches in natural high temperatures and even anaerobic environments. Ecological distribution and phylogenetic analysis of this unique organism will be reported elsewhere.

Acknowledgments

This work was supported by the Grant-in-Aid for Scientific Research no. 06660091 and no. 08660121 from the Ministry of Education, Science, and Culture, Japan.

References

- 1) Suzuki, S., Horinouchi, S., and Beppu, T., Growth of a tryptophanase-producing thermophile, *Symbiobacterium thermophilum* gen. nov., sp. nov., is dependent on co-culture with a *Bacillus* sp. *J. Gen. Microbiol.*, **134**, 2353–2362 (1988).
- 2) Suzuki, S., Hirahara, T., Horinouchi, S., and Beppu, T., Purification and properties of thermostable tryptophanase from an obligately symbiotic thermophile, *Symbiobacterium thermophilum*. *Agric. Biol. Chem.*, **55**, 3059–3066 (1991).
- 3) Hirahara, T., Suzuki, S., Horinouchi, S., and Beppu, T., Cloning, nucleotide sequences, and overexpression in *Escherichia coli* of tandem copies of a tryptophanase gene in an obligately symbiotic thermophile, *Symbiobacterium thermophilum*. *Appl. Env. Microbiol.*, **58**, 2633–2642 (1992).
- 4) Suzuki, S., Hirahara, T., Shim, J.-K., Horinouchi, S., and Beppu, T., Purification and properties of thermostable β -tyrosinase from an obligately symbiotic thermophile, *Symbiobacterium thermophilum*. *Biosci. Biotechnol. Biochem.*, **56**, 84–89 (1992).
- 5) Hirahara, T., Horinouchi, S., and Beppu, T., Cloning, nucleotide sequence, and overexpression in *Escherichia coli* of the β -tyrosinase gene from an obligately symbiotic thermophile, *Symbiobacterium thermophilum*. *Appl. Microbiol. Biotechnol.*, **39**, 341–346 (1993).
- 6) Ferre, F., Marchese, A., Pezzoli, P., Griffin, S., Buxton, E., and Boyer, V., In "The Polymerase Chain Reaction", eds. Mullis, K. B., Ferre, F., and Gibbs, R. A., Birkhauser, Boston. pp. 67–88 (1994).
- 7) Rutledge, E. J., and Sumpter, J. P., Estrogenic activity of surfactants and some of their degradation products assessed using a recombinant yeast screen. *Env. Toxicol. Chem.*, **15**, 241–248 (1996).
- 8) Saito, H., Shibata, T., and Ando, T., Mapping of genes determining nonpermissiveness and host-specific restriction to bacteriophages in *Bacillus subtilis* Marburg. *Mol. Gen. Genet.*, **170**, 117–122 (1979).
- 9) Zhang Zhang, M., Nakai, H., and Imanaka, T., Useful host-vector systems in *Bacillus stearothermophilus*. *Appl. Env. Microbiol.*, **54**, 3162–3164 (1988).
- 10) Maseda, H., and Hoshino, T., Fusion with ribosomal protein L32 increased the in vivo thermostability of kanamycin nucleotidyltransferase in *Thermus thermophilus*. *J. Ferment. Bioeng.*, **82**, 525–530 (1996).
- 11) Guastella, J., Nelson, N., Nelson, H., Czyzyk, L., Keynan, S., Miedel, M. C., Davidson, N., Lester, H. A., and Kanner, B. I., Cloning and expression of a rat brain GABA transporter. *Science*, **249**, 1303–1306 (1990).
- 12) Burnham, C. E., Buerk, B., Schmidt, C., and Bucuvalas J. C., A liver-specific isoform of the betaine/GABA transporter in the rat: cDNA sequence and organ distribution. *Biochim. Biophys. Acta.*, **1284**, 4–8 (1996).
- 13) Lai, X., and Ingram, L. O., Discovery of a *ptsHI* operon, which includes a third gene (*ptsT*), in the thermophile *Bacillus stearothermophilus*. *Microbiol.*, **141**, 1443–1449 (1995).
- 14) Fleischmann, R. D., Adams, M. D., White, O., Clayton, R. A., Kirkness, E. F., Kerlavage, A. R., Bult, C. J., Tomb, J.-F., Dougherty, B. A., Merrick, J. M., McKenney, K., Sutton, G., FitzHugh, W., Fields, C., Gocayne, J. D., Scott, J., Shirley, R., Liu, L.-I., Glodek, A., Kelley, J. M., Weidman, J. F., Phillips, C. A., Spriggs, T., Hedblom, E., Cotton, M. D., Utterback, T. R., Hanna, M. C., Nguyen, D. T., Saudek, D. M., Brandon, R. C., Fine, L. D., Fritchman, J. L., Fuhrmann, J. L., Geoghagen, N. S. M., Gnehm, C. L., McDonald, L. A., Small, K. V., Fraser, C. M., Smith, H. O., and Venter, J. C., Whole-genome random sequencing and assembly of *Haemophilus influenzae* Rd. *Science*, **269**, 496–512 (1995).
- 15) Bult, C. J., White, O., Olsen, G. J., Zhou, L., Fleischmann, R. D., Sutton, G. G., Blake, J. A., FitzGerald, L. M., Clayton, R. A., Gocayne, J. D., Kerlavage, A. R., Dougherty, B. A., Tomb, J. F., Adams, M. D., Reich, C. I., Overbeek, R., Kirkness, E. F., Weinstock, K. G., Merrick, J. M., Glodek, A., Scott, J. L., Geoghagen, N. S. M., and Venter, J. C., Complete genome sequence of the methanogenic archaeon, *Methanococcus jannaschii*. *Science*, **273**, 1058–1073 (1996).